

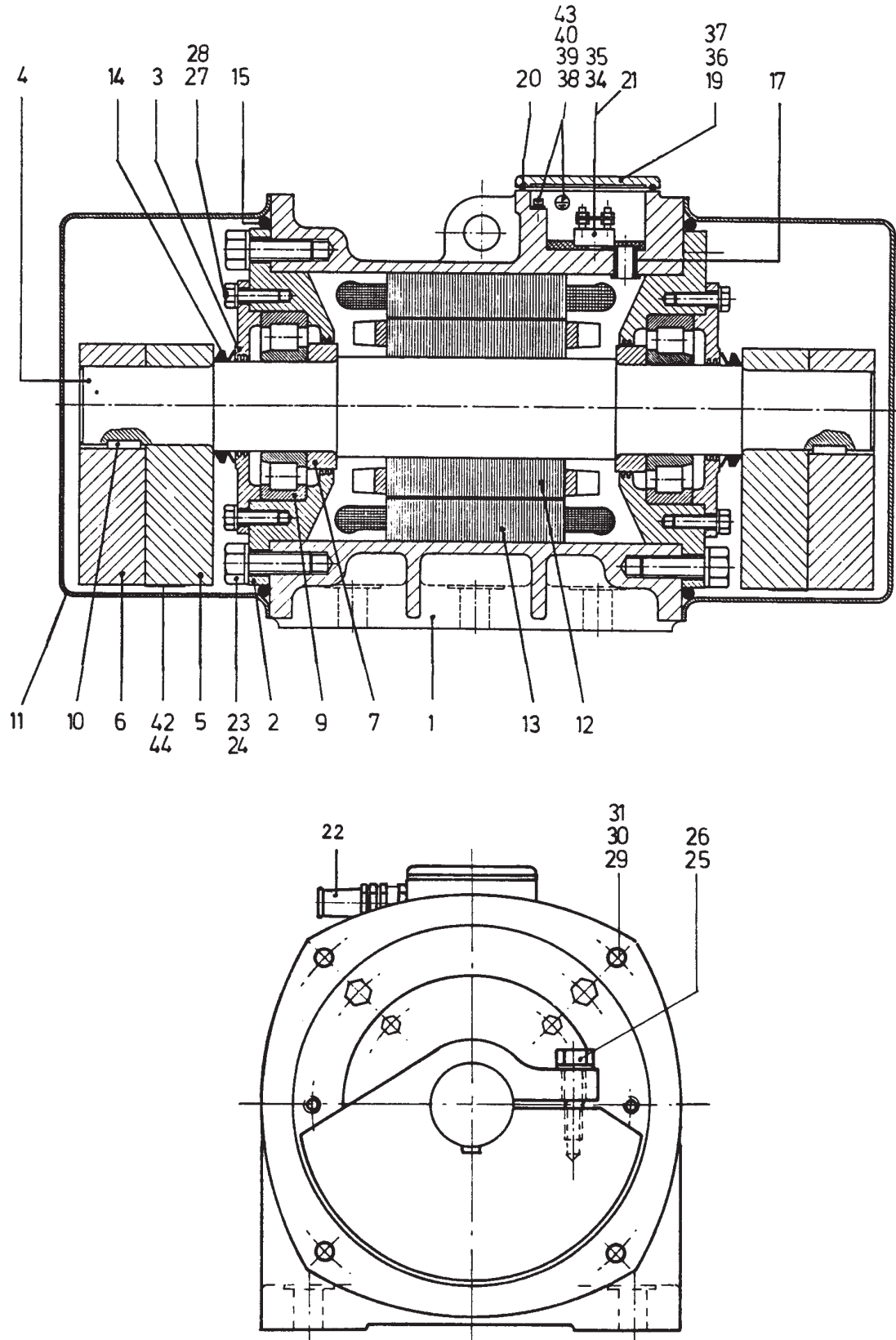





- Ⓓ Ersatzteilliste
- ⒼⒷ Spare parts list
- Ⓕ Liste des pieces de rechange
- Ⓘ Lista parti di ricambio

für Friedrich - Vibrationsmotoren
for Friedrich - Vibration Motors
pour Moteurs à Vibration Friedrich
Motori Vibranti Friedrich

Baugrößen/Sizes/Grandeur/Struttura 2/2.1/2.3/3/3.1/3.3/4/4.1/5/6/7/8/9



Pos.	Benennung 	Description 	Désignation 	Denominazione 
1	Statorgehäuse	Stationary coil housing	Boitier de stator	Involurco statore
2	Lagerschild	Bearing bracket	Flasque-palier	Scudo cuscinetto
3	Lagerdeckel	Bearing cover	Chapeau de palier	Coperchio cuscinetto
4	Welle	Shaft	Arbre	Albero
5	Fliehscheibe (innen)	Segmental flyweight (inner)	Disque centrifuge (int.)	Disco ad inerzia (int.)
6	Fliehscheibe (außen)	Segmental flyweight (outer)	Disque centrifuge (ext.)	Disco ad inerzia (esterno)
7	Distanzring	Spacer ring	Gaque intercalaire	Anello distanziatore
9	Zylinderrollenlager	Cylindrical roller bearings	Roulement à rouleaux	Cuscinetto a rulli cilindrici
10	Paßfeder	Featherkey	Ressort d'ajustement	Linguetta a molla
11	Haube	Casing	Capot à indiquer lors	Calotta (da indicare)
12	Rotor	Rotor	Rotor	Rotore
13	Stator	Stationary coil	Stator	Statore
14	Merkel-Ring	Merkel ring	Anneau Merkel	Anello Merkel
15	Hauben-Abdichtung	Casing gasket	Joint de capot	Guarnizione calotta
17	Gummitülle	Rubber grommet	Passe-fil en caoutch	Boccola gomma
19	Klemmenkasten-Deckel	Terminal box cover	Couvre-Bornes	Coperchio morsetti
20	Rundgummidichtung	Round rubber seal	Garniture toroidale en caout- chouc	Guarnizione gomma sezione cilindrica
21	Klemmenbrett	Terminal plate	Planche à bornes	Supporto morsetti
22	Leitungsstutzen	Cable gland	Manchon passe - câble	Supporto a guaina cavo
23	Sechskantschraube	Hexagon screw	Vis à six pans	Vite a testa esagonale
24	Sicherungsscheibe	Locking plate	Rondelle de sureté	Rondella di sicurezza
25	Sechskantschraube	Hexagon screw	Vis à six pans	Vite a testa esagonale
26	Sicherungsscheibe	Locking plate	Rondelle de sureté	Rondella di sicurezza
27	Sechskantschraube	Hexagon screw	Vis à six pans	Vite a testa esagonale
28	Sicherungsscheibe	Locking plate	Rondelle de sureté	Rondella di sicurezza
29	Sechskantschraube	Hexagon screw	Vis à six pans	Vite a testa esagonale
30	Sicherungsscheibe	Locking plate	Rondelle de sureté	Rondella di sicurezza
31	Sicherheitsmutter	Safety nut	Contre-écrou	
34	Innensechskantschrb.	Socket head screw	Vis à six pans creux	Vite ad esagono incassato
35	Sicherungsscheibe	Locking plate	Rondelle de sureté	Rondella di sicurezza
36	Innensechskantschrb.	Socket head screw	Vis à six pans creux	Vite ad esagono incassato
37	Sicherungsscheibe	Locking plate	Rondelle de sureté	Rondella di sicurezza
38	Innensechskantschrb.	Socket head screw	Vis à six pans creux	Vite ad esagono incassato
39	Federring	Spring water	Rondelle de sureté	Lamiera di sicurezza
40	Erdungszeichen	Earth symbol	Ind. de mise à la terre	Simbolo messa terra
42	Fliehkraftskala	Flyweight dial	Cadran Centrifuge	Scala graduata forza centrifuga
43	Ergungsklemme	Earth clip	Borne de mise à terre	Messa a terra di sicurreza
44	Halbrundkerbnagel	Round-headed grooved pins	Clou cannelé à tete ronde	Chiodo rigato a testa semisferca
45	Leistungsschild	Name plate	Plaquette signalétique	Targhetta motore
Bestelldaten		Ordering datas	Donnés de commande	Data d. spedizioni
Type:		Typ:	Type:	Tipo:
Serien-Nr.:		Serial-No.:	No. de moteur:	No. di serie:
Spannung:		Voltage:	Voltage:	Tensione:
Pos.-Nr.:		Pos.No.:	No.de pos.:	No. di pos.:
Stückzahl:		Quantity:	Quantité:	Pezzo: